

### 38Z-METER TRUCK-MOUNTED SPECIFICATIONS

Length	39' 3"	(11.97m)
Width	8' 2"	(2.50m)
Height	12' 11"	(3.94m)
Wheelbase	215"	(5,461mm)
Front axle weight	19,400 lbs	(8,800kg)
Rear axle weight	37,400 lbs	(17,000kg)
Approx total weight	56,800 lbs	(25,800kg)

Based on Model MACK MRU 613 with .16H pump cell.  
Weights are approximate and include pump, boom, truck, driver and some fuel. Varies with options selected.  
Dimensions will vary with different truck makes, models and specifications.

### BOOM SPECIFICATIONS | MULTI-Z DESIGN

#### Height & Reach

Vertical reach	121' 9"	(37.11m)
Horizontal reach	108' 7"	(33.10m)
Reach from front of truck*	101' 1"	(30.81m)
Reach depth	80' 1"	(24.41m)
Unfolding height	28' 7"	(8.71m)

#### 4-Section Boom

1st section articulation	103°	
2nd section articulation	180°	
3rd section articulation	245°	
4th section articulation	233°	
1st section length	28' 6"	(8.69m)
2nd section length	25' 3"	(7.70m)
3rd section length	27' 7"	(8.41m)
4th section length	27' 3"	(8.31m)

#### General Specs

Pipeline Size (ID) metric ends	5"	(125mm)
Rotation	365°	
End hose — length	10' 0"	(3.00m)
End hose — diameter	5"	(125mm)
Outrigger spread L - R — front	20' 8"	(6.30m)
Outrigger spread L - R — rear	21' 3"	(6.50m)
Outrigger spread L - R — front hydraulically extend out & down		
Outrigger spread L - R — rear hydraulically swing out & extend down		

### PUMP SPECIFICATIONS

	38Z.16H	38Z.18H LS
Output — rod side	210 yd <sup>3</sup> /hr (160m <sup>3</sup> /hr)	—
Output — piston side	141 yd <sup>3</sup> /hr (108m <sup>3</sup> /hr)	238 yd <sup>3</sup> /hr (182m <sup>3</sup> /hr)
Pressure — rod side	1,233 psi (85 bar)	—
Pressure — piston side	1,885 psi (130 bar)*	1,233 psi (85 bar)
Material cylinder diameter	9" (230mm)	10" (250mm)
Stroke length	83" (2,100mm)	83" (2,100mm)
Maximum strokes per minute — rod side	31	—
Maximum strokes per minute — piston side	21	29
Volume control	0-Full	0-Full
Vibrator	Standard	Standard
Hard-chromed material cylinders	Standard	Standard
Hydraulic system	Free Flow	Free Flow
Hydraulic system pressure	5,075 psi (350 bar)	5,075 psi (350 bar)
Differential cylinder diameter	5.5" (140mm)	5" (125mm)
Rod diameter	3.1" (80mm)	3.1" (80mm)
Maximum size aggregate	2.5" (63mm)	2.5" (63mm)
Water tank	185 gal (700L)	185 gal (700L)

Maximum theoretical values listed.  
\* Applies to units mounted on PMA stock truck — MACK MRU 613  
• Standard delivery line system rated at max line pressure of 1,233 psi (85 bar)

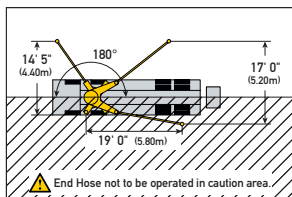
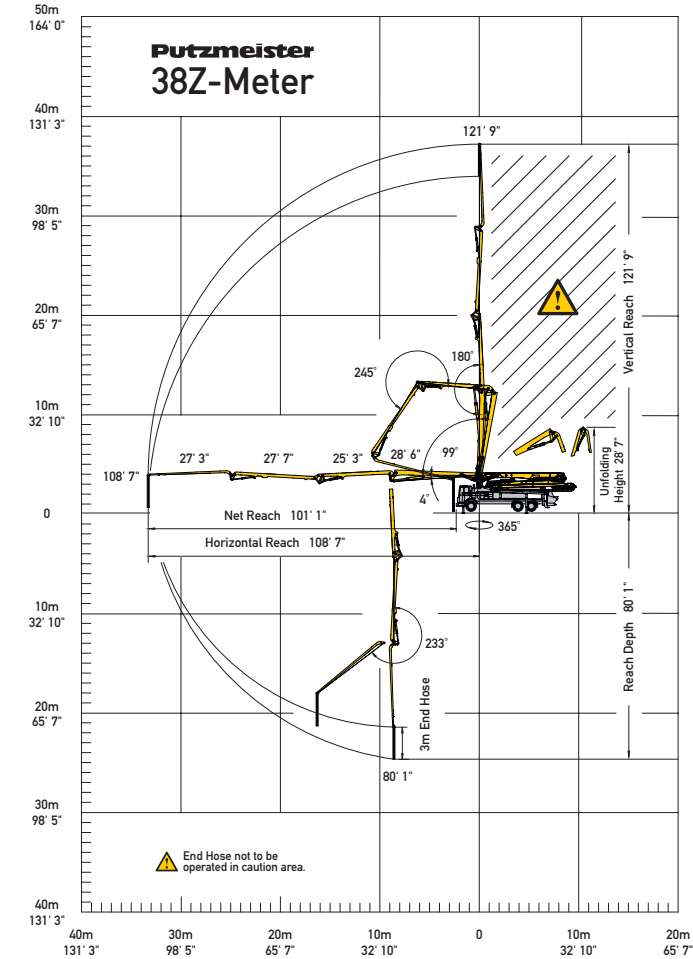

With One-Sided Support (OSS) 180°

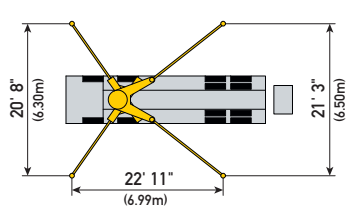

Photos and drawings are for illustrative purposes only.

Authorized Distributor

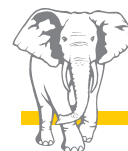
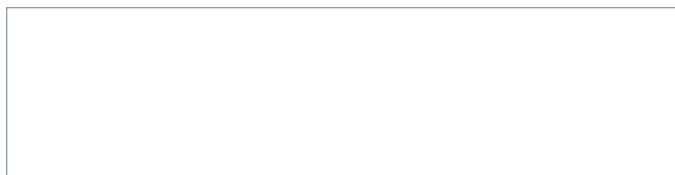

**Putzmeister**

Putzmeister America, Inc. Phone (262) 886-3200  
1733 90th Street Toll-free (800) 884-7210  
Sturtevant, WI 53177 USA Fax (262) 884-6338

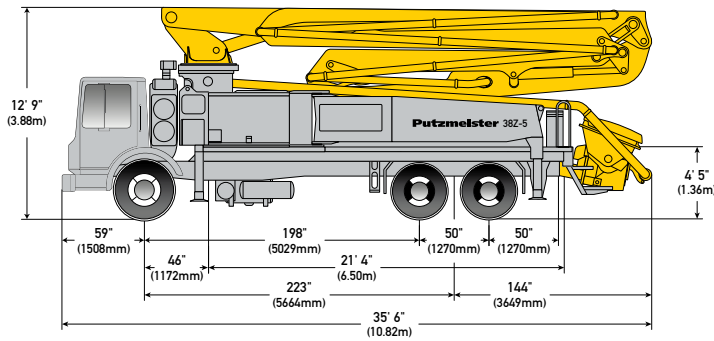

### 38Z-5-METER TRUCK-MOUNTED SPECIFICATIONS

Length	35' 6"	(10.82m)
Width	8' 2"	(2.50m)
Height	12' 9"	(3.88m)
Wheelbase	223"	(5,664mm)
Front axle weight	18,620 lbs	(8,446kg)
Rear axle weight	35,980 lbs	(16,320kg)
Approx. total weight	54,600 lbs	(24,766kg)

Based on Model MACK MRU 613 with .16H pump cell.  
Weights are approximate and include pump, boom, truck, driver and full fuel tank.  
Varies with options selected.  
Dimensions will vary with different truck makes, models and specifications.

### BOOM SPECIFICATIONS | Z-FOLD DESIGN

<b>Height &amp; Reach</b>		
Vertical reach	123' 0"	(37.50m)
Horizontal reach	107' 7"	(32.80m)
Reach from front of truck*	99' 5"	(30.30m)
Reach depth	83' 0"	(25.30m)
Unfolding height	24' 3"	(7.40m)

<b>5-Section Boom</b>		
1st section articulation	90°	
2nd section articulation	180°	
3rd section articulation	180°	
4th section articulation	245°	
5th section articulation	230°	
1st section length	28' 7"	(8.70m)
2nd section length	20' 4"	(6.20m)
3rd section length	18' 5"	(5.60m)
4th section length	21' 4"	(6.50m)
5th section length	21' 4"	(6.50m)

<b>General Specs</b>		
Pipeline Size (ID) metric ends	5"	(125mm)
Rotation	365°	
End hose — length	10' 0"	(3.00m)
End hose — diameter	5"	(125mm)
Outrigger spread L - R — front	20' 8"	(6.30m)
hydraulically extend out & down		
Outrigger spread L - R — rear	23' 11"	(7.30m)
hydraulically swing out & extend down		

PUMP SPECIFICATIONS		38Z-5.16H	38Z-5.18H LS
Output — rod side	210 yd <sup>3</sup> /hr (160m <sup>3</sup> /hr)		—
— piston side	141 yd <sup>3</sup> /hr (108m <sup>3</sup> /hr)		238 yd <sup>3</sup> /hr (182m <sup>3</sup> /hr)
Pressure — rod side	1,233 psi (85 bar)		—
— piston side	1,885 psi (130 bar)*		1,233 psi (85 bar)*
Material cylinder diameter	9" (230mm)		10" (250mm)
Stroke length	83" (2,100mm)		83" (2,100mm)
Maximum strokes per minute — rod side	31		—
— piston side	21		29
Volume control	0-Full		0-Full
Vibrator	Standard		Standard
Hard-chromed material cylinders	Standard		Standard
Hydraulic system	Free Flow		Free Flow
Hydraulic system pressure	5,075 psi (350 bar)		5,075 psi (350 bar)
Differential cylinder diameter	5.5" (140mm)		5.5" (140mm)
Rod diameter	3.1" (80mm)		3.1" (80mm)
Maximum size aggregate	2.5" (63mm)		2.5" (63mm)
Water tank— pedestal	185 gal (700L)		185 gal (700L)

Maximum theoretical values listed.  
\* Applies to units mounted on PMA stock truck — MACK MRU 613  
• Standard delivery line system rated at max line pressure of 1,233 psi (85 bar)

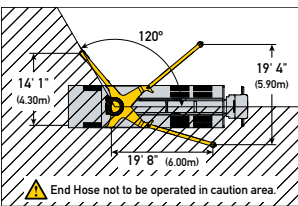
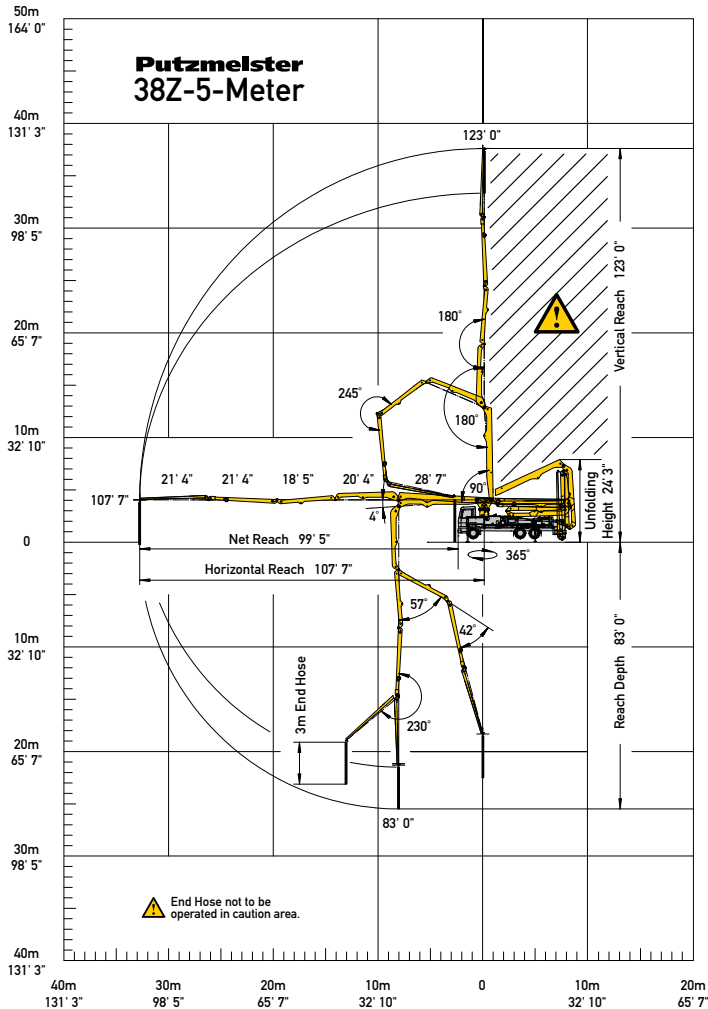

Optional One-Sided Support (OSS) 120°

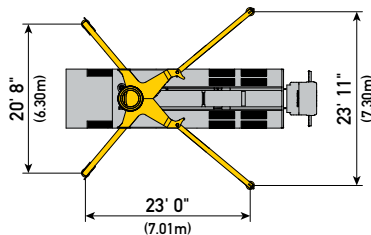

Photos and drawings are for illustrative purposes only.

Authorized Distributor

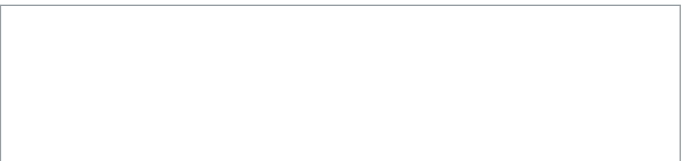

Putzmeister America, Inc. Phone (262) 886-3200  
1733 90th Street Toll-free (800) 884-7210  
Sturtevant, WI 53177 USA Fax (262) 884-6338

PutzmeisterAmerica.com

pmr@putzam.com

CB 4246-2 US



© Putzmeister America, Inc. 2017

Printed in the USA (1.51701)